

Re-handling Clamshell Bucket

C60H / C80H

Durable Re-handling Clamshell Bucket, especially for loading bulk materials for excavators from 40t to 60t (C80H: 80t) operating weight.

- maximum volume due to widely spaced pivots with a flat closing curve. Protection of the ground surface is guaranteed, e.g. discharge from boat and train carriages etc.
- Precise positioning with an integrated rotator
- long life is ensured due to the use of 500 HB steel in the manufacture of cutting edges
- robust, fully integrated rotator that is fixed at 4 points to withstand external forces, with pressure relief valve to ensure overload protection, with connecting hoses located inside the hub
- integrated non-return valve guarantees security of the load
- excellent digging characteristics are the result of high closing forces (74 kN at an operating pressure of 35 MPa. With C80H even 95 kN)



C60H

Re-handling Clamshell Bucket C60H / C80H

| Type | Opening A (mm) | Width B (mm) | Height C (mm) | Volume (litre) | Self weight (kg) | Load capacity (kg) | Torque (Nm) |
|----------|----------------------|--------------------|---------------------|-------------------|---------------------|-----------------------|----------------|
| C60H-125 | 2735 | 1250 | 1560 | 1875 | 1700 | 9000 | 3000 |
| C60H-150 | 2735 | 1500 | 1560 | 2250 | 1800 | 9000 | 3000 |
| C60H-175 | 2735 | 1750 | 1560 | 2625 | 1900 | 9000 | 3000 |
| C60H-200 | 2735 | 2000 | 1560 | 3000 | 2000 | 9000 | 3000 |
| C60H-250 | 2735 | 2500 | 1560 | 3750 | 2760 | 9000 | 3000 |
| C80H-125 | 3050 | 1250 | 1960 | 2500 | 2400 | 10000 | 3000 |
| C80H-150 | 3050 | 1500 | 1960 | 3000 | 2500 | 10000 | 3000 |
| C80H-175 | 3050 | 1750 | 1960 | 3500 | 2600 | 10000 | 3000 |
| C80H-200 | 3050 | 2000 | 1960 | 4000 | 2700 | 10000 | 3000 |
| C80H-250 | 3050 | 2500 | 1960 | 5000 | 3000 | 10000 | 3000 |

Package consists of:

Re-handling Clamshell Bucket, integrated **KINSHOFER** rotator with 4 fixing points (pin-Ø 70/width 180 mm) and non-return valve

Accessories

| Type | Description |
|----------------|---|
| KM 501 19t-60t | upper suspension without pendulum damper |
| KM 511 19t-60t | upper suspension with pendulum damper |
| SW40 cardanic | adapter for Lehnhoff grab exchange system SW/MS40 without suspension – up to 70t adapter for quick exchange systems from other manufacturers available |

Requirements of Excavator

| | C60H | C80H |
|--------------------------------------|-----------------------|-----------------------|
| Operating pressure (open/close): | max. 35 MPa (350 bar) | max. 35 MPa (350 bar) |
| Operating pressure (rotate): | max. 17 MPa (170 bar) | max. 17 MPa (170 bar) |
| Pump capacity (open/close): | 100 - 250 l/min | 100 - 300 l/min |
| Pump capacity (rotate): | 25 - 60 l/min | 25 - 60 l/min |
| Hydraulic connection (grab/rotator): | G 1/2" / G 3/4" | G 1/2" / G 3/4" |

Technical Drawings

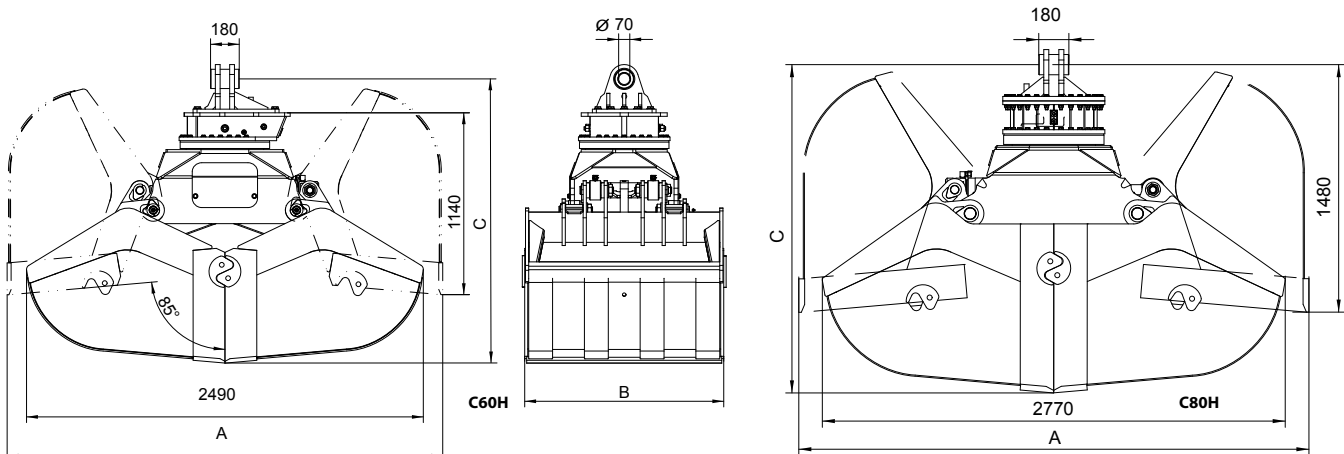

C60H

C80H

