

Heavy Duty Demolition and Sorting Grabs

D15H-P HD to D70H-P HD

Robust multi-purpose grab with perforated shells, for excavators from 10t / 22000 lbs up to 80t / 176000 lbs operating weight, the HD D Series grabs are ideal for demolition and sorting of all kinds of building materials.

- Robust Delta-box frame with dust-proof axle bearing points.
- Perforated shells let fine dust and gravel through without large pieces getting caught.
- Durable and reversible cutting edges, made of Cracox Plus 450 steel can be used to pick up different materials, with their tips.
- Cutting edges on D19 series and higher can be turned three ways, reducing replacement costs.
- Robust, fully integrated rotator with sturdy slewing ring to withstand external forces, with pressure relief valve to ensure overload protection, and connecting hoses protected inside the hub.
- Exceptional closing forces achieved with a horizontally positioned hydraulic cylinder that is protected by the bucket carrier.
- Cylinder is hydraulically cushioned.



D70H-P-150HD

Heavy Duty Demolition and Sorting Grabs with perforated shells D15H-P-75HD to D70H-P150HD

Type	Width E (mm/in)	Opening A (mm/in)	Height C (mm/in)	Volume (litre/c.y.)	Weight (kg/lbs)	Load (kg/lbs)	Closing force (kN/lbf)	Torque (Nm/ft.lbs)	Operating weight (t/lbs)
D15H-P-75HD	750 / 29.53	1730 / 68.11	1295 / 50.98	340 / 0.44	860 / 1892	5000 / 11000	43 / 9460	3000 / 2215	10 – 18 / 22000-39600
	900 / 35.43	1730 / 68.11	1295 / 50.98	415 / 0.54	900 / 1980	5200 / 121000	43 / 9460	3000 / 2215	12 – 20 / 26400-44000
D19H-P-85HD	850 / 33.46	1755 / 69.09	1320 / 51.97	365 / 0.48	1030 / 2266	6500 / 14300	50 / 11000	3000/5700 / 2215/4205*	12 – 24 / 26400-52800
	1000 / 39.37	1895 / 74.61	1400 / 55.12	460 / 0.60	1120 / 2464	7000 / 15400	50 / 11000	3000/5700 / 2215/4205*	13 – 25 / 28600-55000
D24H-P-100HD	1000 / 39.37	1990 / 78.35	1455 / 57.28	570 / 0.75	1315 / 2893	8000 / 17600	56 / 12320	3000/5700 / 2215/4205*	15 – 30 / 33000-66000
	1100 / 43.34	2195 / 86.42	1565 / 61.61	825 / 1.08	1820 / 4004	10500 / 23100	70 / 15400	7000 / 5165**	20 – 40 / 44000-88000
D40H-P-125HD	1250 / 49.21	2355 / 92.72	1640 / 64.57	960 / 1.26	2210 / 4422	13500 / 29700	80 / 17600	7000 / 5165**	25 – 50 / 55000 -110000
	1400 / 55.12	2355 / 92.72	1650 / 64.96	1075 / 1.41	2330 / 5126	16500 / 36300	80 / 17600	7000 / 5165**	35 – 60 / 7700-132000
D70H-P-150HD	1500 / 59.05	2730 / 107.38	1930 / 75.98	1660 / 2.17	4000 / 8800	23500 / 51700	140 / 30800	9000 / 6640**	50 – 80 / 110000-176000

Package consists of: demolition and sorting grab, integrated rotation with sturdy slewing ring, cutting edges and non-return valve

Optional second heavy duty motor for D19H-P HD, D20H-P HD, D24H-P HD

Notes: * optional with 2 motors for rotation ** second heavy duty hydraulic motor comes standard

Accessories

Type	Description
KM 690 15t	adapters for rigid mounting – for excavators up to 15t / 33000 lbs
KM 690 20t	adapters for rigid mounting – for excavators up to 20t / 44000 lbs
KM 690 27t	adapters for rigid mounting – for excavators up to 27t / 59400 lbs
KM 690 32t	adapters for rigid mounting – for excavators up to 32t / 70400 lbs
KM 690 40t	adapters for rigid mounting – for excavators up to 40t / 88000 lbs
KM 690 50t	adapters for rigid mounting – for excavators up to 50t / 110000 lbs
KM 690 70t	adapters for rigid mounting – for excavators up to 70t / 154000 lbs
OQ	bolt-on adapter for Oilquick OQ – 5t up to 70t / 11000 lbs up to 154000 lbs
KSW21 rigid	bolt-on-adapter for „System Lehnhoff“ KMS21/KHS21 for rigid mounting – up to 28t / 61600 lbs adapters for quick change systems – from other manufacturers or different sizes available on request

Requirements of Excavator

Operating pressure (open/close):	D15 - D70: max. 35 MPa (350 bar) / 5040 psi
Recommended oil flow (open/close):	D15 / D16: max. 80 l/min / max. 21.14 GPM; D19 - D24: max. 100 l/min / max. 26.42 GPM; D32 - D50: max. 120 l/min / max. 31.70 GPM; D70: max. 200 l/min / max. 52.84 GPM
Hydraulic connection (grab/rotate):	D15 - D24: G 3/4" / G 1/2"; D32 - D50: G 1" - 25S / G 1/2"; D70: G 1 1/4" - 30S
Operating pressure (rotation):	D15 - D70: max. 14 Mpa (140 bar) / 2016 psi
Recommended oil flow (rotation):	D15 - D24: max. 40 l/min / max. 10.57 GPM; D32 - D70: 40 - max. 60 l/min / 10.57 - max. 15.85 GPM

Technical Drawings

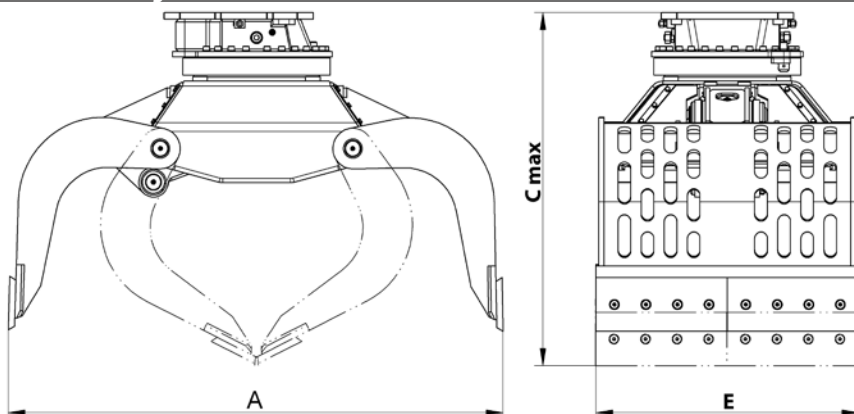

D40H-P-125HD