



HYDRAULIC BREAKERS KSB and KFX



BREAK THE SMART WAY...

KSB-Series for excavators up to 12,5t

The KSB breaker series, for excavators from 0.5 to 12,5t, benefits from a distinctive 'monobloc' design, manufactured in a single piece and without any tie rods – a feature that makes the structure extremely durable and resistant to leverage during operation.

The breakers all work with nitrogen inertial energy recovery – a gas that provides greater machine power and less stress on the excavator arm. Traditionally, breakers with nitrogen energy re-recovery require frequent recharges – but with the new KSB-range's special sealing system, the charge-life can be increased by up to 300%. The series offers unrivalled stability in nitrogen pressure whilst remaining tolerant to back pressure. The distinctive sealed casing design is also sound-proofed, emitting low noise levels during operation.

The new KSB-series has a wide calibration range of the required oil flow for an easier setup.

The tapered shape also ensures excellent visibility during operation, allowing the operator to work close to walls and other structures.

The hose routing is favourable as hoses are within the width of the breaker.

There are seven different tool versions available for many tasks.



Tools for KSB-Series



Moil Point

Suitable for concrete, medium-hard and non-layered rock.



Blunt Tool

Suitable for reinforced concrete and highly compact rock.



Pyramid Tool

Suitable for reinforced concrete and highly compact rock.



Chisel Tool

Suitable for medium-hard and layered rock.



Wood Cutter Tool

Suitable for cutting all types of wood.



Pile Driver

Suitable for planting wooden or concrete poles and posts.



Asphalt Cutter

Suitable for cutting asphalt.





1 More power, less vibration and maintenance

The KSB breakers work with inertial nitrogen energy recovery, thus obtaining more power (more than 30%) and less vibration thanks to the nitrogen chamber that reduces maintenance costs, since it has no diaphragm.

2 Long lasting of the nitrogen charge

In the past, energy recovery breakers required frequent nitrogen refills; with the new sealing system and the new compound developed by Freudenberg they are able to guarantee a gas tightness equal to 300% more than in the past.

3 Protected tubes

The tubes are completely protected through the casing and they're suitable for every type of excavation, especially in narrow spaces.

4 Silenced body

The particular design, with a closed box casing as well as the insertion of sound-absorbing material, allowed to reach very low noise levels for a breaker.

5 Double retainer pin

The tool locking system with double retainer pin allows an adequate and uniform wear of the same and ensures longer maintenance intervals for the whole locking system.

6 Monoblock body without tie rods

The entire KSB series benefits from the particular monoblock construction; this feature gives the structure a very high resistance to leverage, during work. The breaker is built in one only piece and it is without tie rods, thus obtaining greater production and less maintenance as a result.

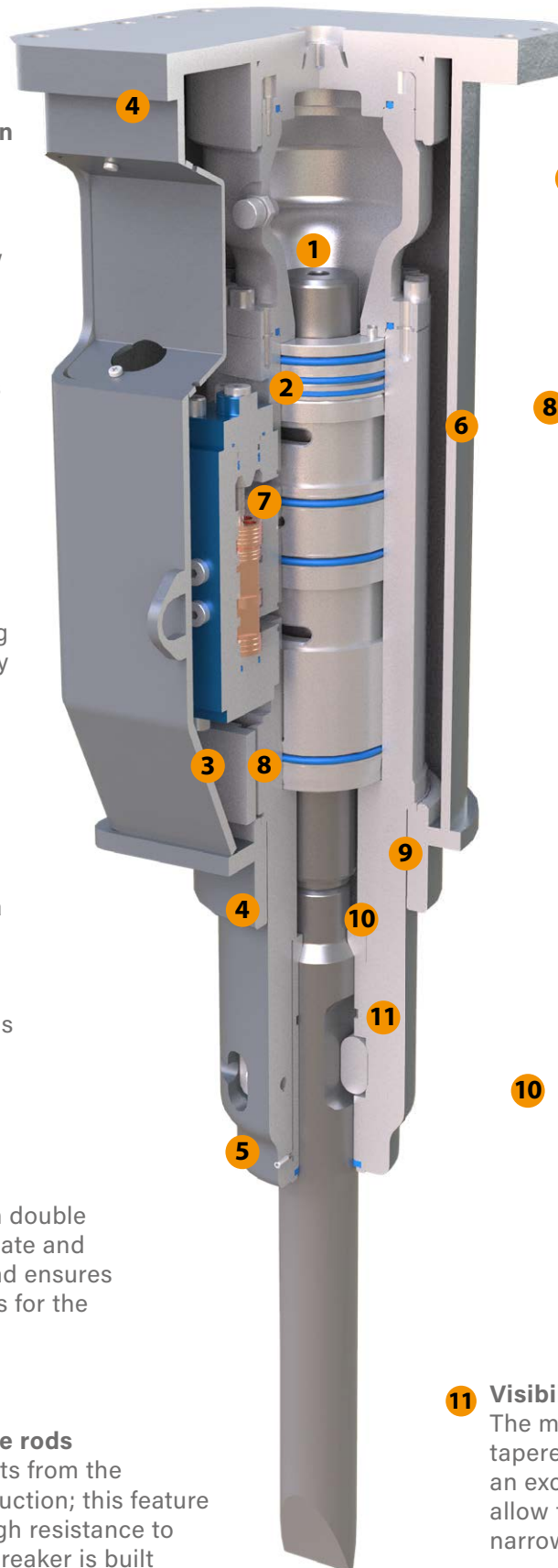

7 Only two moving parts

8 For all types of installations (pressurization)

The KSB series tolerates high back pressure and it has a wide calibration range of the required oil flow, in order to get the installation easier.

9 The piston moves in a single interchangeable cylinder liner that keeps the main body intact and that is easy to replace in case of necessity.

10 The piston is built with a special geometry such as to keep a constant energy of impact, as well as for reducing breakages in conditions of criticality.

11 Visibility and versatility

The models of the KSB series, with their tapered shape, provide the operator with an excellent view during the work and allow to operate close to the walls, both in narrow section and with open front.

...A SMART CHOICE!

KFX-Series for excavators up to 200t

The KFX breaker-series, for excavators from 8 to 200t, has two adjusting valves as standard. Firstly, a control valve on the cylinder of the hammer allows the operator to adjust the number of blows generated. A second valve allows the adjustment of the working pressure from 16 to 20 MPa.

The standard, inner pipes provide direct greasing of the lower bushing and spacer, improving the longevity of retainer pins and bushings.

Working in tunnels, and even underwater, is also possible by adding air tubes. The KFX breaker-series is available with a range of five different tools, suitable for penetrating a variety of surface structures.

There are five different tool versions available for many tasks.



Tools for KFX-Series



Moil Point

Suitable for concrete, medium-hard and non-layered rock.



Blunt Tool

Suitable for reinforced concrete and highly compact rock.



Pyramid Tool

Suitable for reinforced concrete and highly compact rock.



Chisel Tool

Suitable for medium-hard and layered rock.



Cobra Tool

Suitable for quarry works such as primary demolition and block reduction.

Options for KFX-Series

Gallery Kit

A specific system for heavy-duty gallery work, to extend maintenance intervals and reduce costs – comprising bushes and pistons suitable for such a tough working environment. A spray mist kit option for dust abatement is also available, which directs a strong water jet over the tool operation area.

Underwater Kit

Avoid water entering the breaker with a specific underwater kit, for use in the most demanding of environments.

Automatic Greaser for all KFX Models

Greases automatically using the breaker's pressure line to save time and increase productivity – available for mounting on all breaker ranges.

1 Tubes with swivels fully protected from any bad uses and resistant to vibrations in case of lack of nitrogen in the chamber.

2 **Regulation of the operating pressure**
For the KFX-series (KFX 16 to KFX 200), it is possible to adjust the working pressure by a manual valve located frontally, on the distribution of the breaker.

3 **Anti-dust and underwater work set up**
You can prevent the entry of dust and water into the breaker by blowing air into the proper hole in the front part of the breaker, with a pressure not less than 10 bar.

4 **Automatic hydraulic greasing device (optional, mounted on the breaker)**
The Beka-Lube automatic lubrication system optimizes the lubrication procedure and reduces maintenance and downtimes.

5 **Automatic hydraulic greasing device with electric control (optional, mounted on the excavator)**
Innovative electric system with automatic grease distribution, less liable to vibration breakages thanks to its own tank of grease with a capacity of 4 kg or 8 kg, making thus the system cheaper than all the other devices with single cartridges.

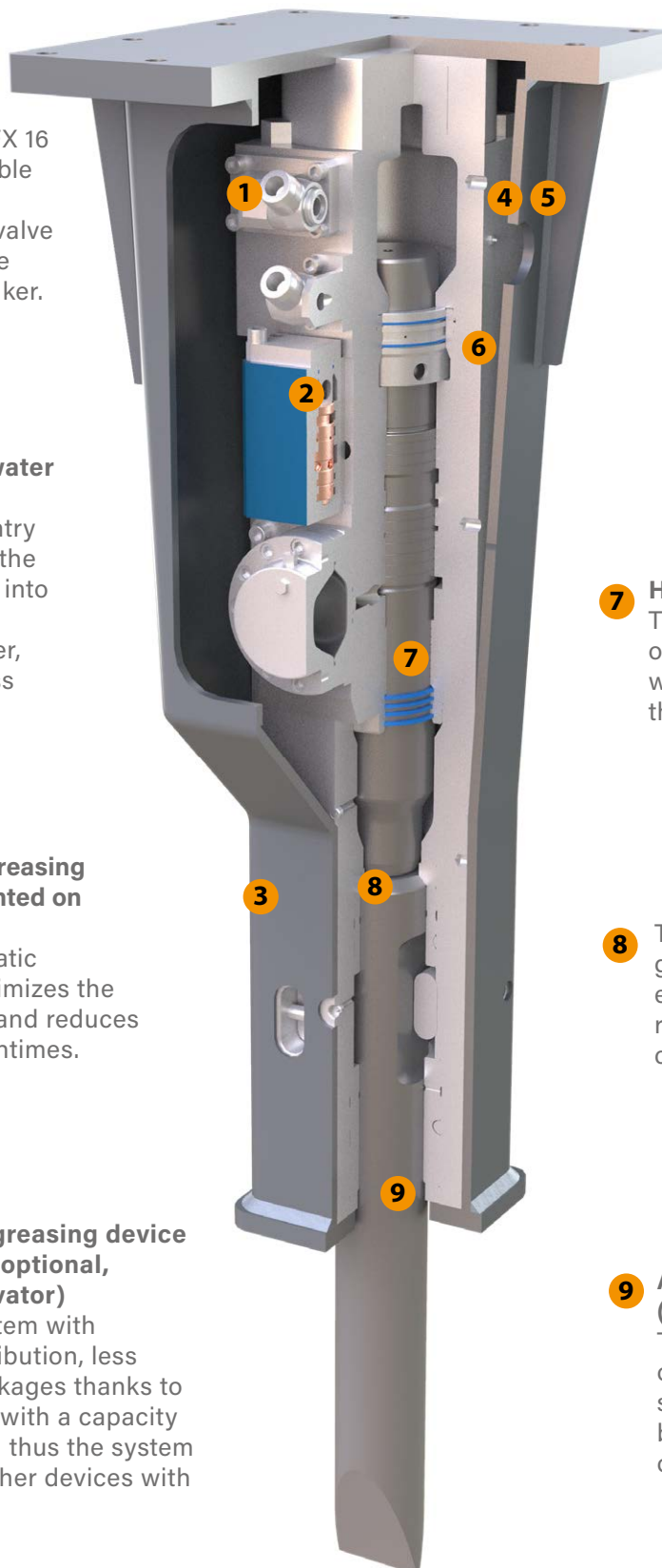

6 **Manual adjustment of blows**
For the KFX-series (KFX 16 to KFX 200), the regulation of the blows is carried out manually by an adjusting valve located on the side of the breaker.

7 **Hydraulic system for blank firings**
The hydraulic system is a regenerative oil circuit that avoids blank firings when the tool is not in contact with the rock.

8 The piston is built with a special geometry such as to keep a constant energy of impact, as well as for reducing breakages in conditions of criticality.

9 **Anti-dust system for tunnels (optional)**
The anti-dust system consists of the addition of a dustproof seal mounted in the lower bush so to avoid the entering of impurities in the circuit.

The breakers of the KFX-series, thanks to their power and efficiency and to the right ratio between weight and power, are suitable for secondary demolition work, excavations in quarry, work in urban areas, tunnels, pipelines and railway tunnels and, concerning the biggest models, demolitions in open pit mining.

KSB Hydraulic Breakers

Technical Key Features KSB

Type	Operating weight (t)	Weight of breaker (kg)	Height with standard tool (mm)	Chisel diameter (mm)	Blows per minute (/min)	Energy (J)
KSB 0	0.5 - 1.4	60	785	40	800 - 1,700	250
KSB 1	0.5 - 1.6	70	810	40	800 - 1,750	280
KSB 2	1.2 - 2.5	100	920	45	800 - 2,300	400
KSB 3	1.5 - 3.8	135	920	48	800 - 2,000	580
KSB 4	2.5 - 5.0	190	1,145	55	900 - 1,900	750
KSB 6	3.0 - 6.5	240	1,170	65	850 - 1,800	950
KSB 8	4.5 - 8.5	300	1,200	75	600 - 1,500	1,200
KSB 10	6.0 - 10.0	430	1,515	80	500 - 1,300	1,700
KSB 12	8.0 - 12.5	480	1,565	90	600 - 1,200	2,300

Hydraulics KSB

Type	Oil flow (l/min)	Operating pressure (bar)	Back pressure max. (bar)	Nominal diameter pressure line	Nominal diameter tank line
KSB 0	15 - 20	110	30	1/2"	1/2"
KSB 1	13 - 20	100	30	1/2"	1/2"
KSB 2	15 - 30	110	30	1/2"	1/2"
KSB 3	18 - 40	110	30	1/2"	1/2"
KSB 4	25 - 55	130	30	1/2"	1/2"
KSB 6	30 - 60	140	30	1/2"	1/2"
KSB 8	50 - 70	160	30	3/4"	3/4"
KSB 10	75 - 90	150	30	3/4"	3/4"
KSB 12	85 - 110	150	30	3/4"	3/4"

KFX Hydraulic Breakers

Technical Key Features KFX

Type	Operating weight (t)	Weight of breaker (kg)	Height with standard tool (mm)	Chisel diameter (mm)	Blows per minute (/min)	Energy (J)
KFX 16	10 - 17	950	1,940	115	600 - 900	2,600
KFX 20	13 - 19	1,200	2,030	120	400 - 900	3,200
KFX 26	18 - 24	1,650	2,290	135	400 - 800	4,200
KFX 29	22 - 27	1,850	2,515	140	400 - 800	4,700
KFX 32	23 - 31	2,200	2,560	150	400 - 800	5,400
KFX 36	28 - 38	2,900	2,740	160	350 - 700	8,500
KFX 40	30 - 40	3,200	2,740	160	300 - 650	9,000
KFX 47	35 - 50	3,700	3,040	180	300 - 650	9,500
KFX 58	36 - 55	4,400	3,040	180	300 - 650	12,500
KFX 70	40 - 65	4,850	3,090	195	250 - 550	16,500
KFX 80	45 - 75	5,800	3,010	195	250 - 550	18,500
KFX 120	60 - 110	7,800	2,560	215	200 - 400	23,000
KFX 150	80 - 170	12,000	2,740	255	150 - 300	28,000
KFX 200	100 - 200	14,500	2,740	280	150 - 250	35,000

Hydraulics KFX

Type	Oil flow (l/min)	Operating pressure (bar)	Back pressure max. (bar)	Nominal diameter pressure line	Nominal diameter tank line
KFX 16	90 - 120	165	25	1"	1"
KFX 20	110 - 140	170	25	1"	1"
KFX 26	130 - 160	180	25	1"	1"
KFX 29	140 - 180	180	25	1"	1"
KFX 32	165 - 190	180	25	1" 1/4	1" 1/4
KFX 36	180 - 240	180	25	1" 1/4	1" 1/4
KFX 40	200 - 260	180	25	1" 1/4	1" 1/4
KFX 47	250 - 300	180	25	1" 1/4	1" 1/4
KFX 58	270 - 320	190	25	1" 1/4	1" 1/4
KFX 70	290 - 350	190	30	1" 1/4	1" 1/4
KFX 80	300 - 380	190	30	1" 1/4	1" 1/4
KFX 120	380 - 440	190	30	1" 1/4	1" 1/4
KFX 150	480 - 570	190	30	1" 1/2	1" 1/2
KFX 200	500 - 600	190	30	1" 1/2	1" 1/2

All packages consist of: breaker body, two standard tools (chisel, blunt, moil or pyramid) and Nitrogen adapter

KINSHOFER Branches

Hauptsitz Deutschland:
KINSHOFER GmbH
Raiffeisenstrasse 12
83607 Holzkirchen
Tel.: +49 (0) 8021 88 99 0
Email: info@kinshofer.com
www.kinshofer.com

United Kingdom:
KINSHOFER UK Ltd.
Shipton Downs Farm
Hazleton
Cheltenham, Gloucestershire, GL54 4DX
Tel.: +44 (0) 161 406 7046
Fax: +44 (0) 161 406 7014
Email: sales-uk@kinshofer.com
www.kinshofer.com

France:
KINSHOFER France S.A.R.L.
8 Bis, rue Gabriel Voisin, CS 40003
F-51688 Reims Cedex 2
Tel.: +33 (0) 3 88 39 55 00
Fax: +33 (0) 3 88 79 06 75
Email: sales-france@kinshofer.com
www.kinshofer.com

Canada:
KINSHOFER North America
5040 Mainway Drive, Unit #11
Burlington, ON L7L 7G5
Tel.: +1 (905) 335-2856
Fax: +1 (905) 335-4529
Toll Free (North America): 1-800-268-9525
Email: sales-northamerica@kinshofer.com
www.kinshofer.com

United States of America:
KINSHOFER USA
6420 Inducon Drive
Suite G
Sanborn, NY, 14132
Tel.: +1 (716) 731-4333
Toll Free (North America): 1-800-268-9525
Email: sales-usa@kinshofer.com
www.kinshofer.com



KINSHOFER is an
ISO 9001 certified Company.
DVS ZERT is a registered trademark
of DVS ZERT e.V., Düsseldorf.

KINSHOFER Subsidiaries

Nederland:
DEMAREC B.V.
De Hork 32
NL-5431 NS Cuijk
Tel.: +31 (0) 485 442300
Fax: +31 (0) 485 442120
info@demarec.com
www.demarec.com

Sverige:
RF System AB
Furutorpsgatan 6
SE-288 34 Vinslöv
Tel.: +46 (0) 44 817 07
Fax: +46 (0) 44 859 63
Email: info@rf-system.se
www.rf-system.se

United Kingdom:
Auger Torque Europe Limited
Hazleton
Cheltenham, GL54 4DX
Tel.: +44 (0) 1451 861 652
Fax: +44 (0) 1451 861 660
Email: sales@augertorque.com
www.augertorque.com

Australia:
Auger Torque Australia Pty Ltd.
481 Boundary Road, Darra
Queensland 4076
Tel.: +61 (0) 7 3274 2077
Fax: +61 (0) 7 3274 5077
Email: sales@augertorque.com.au
www.augertorque.com.au

Australia:
Doherty Couplers & Attachments Ltd.
PO Box 701,
Annerley (Brisbane) QLD, 4103
Tel.: +61 1 800 057 021
Email: sales@dohertydirect.net
www.dohertydirect.net

New Zealand:
Doherty Engineered Attachments Ltd.
PO Box 9339, Greerton
Tauranga 3142
Tel.: +64 7 574 3000
Fax: +64 7 574 8030
Email: sales@dohertydirect.net
www.dohertydirect.net

United States of America:
Solesbee's LLC
2640 Jason Industrial Parkway
Winston, GA 30187
Toll Free (North America): 1-800-419-8090
Email: sales@solesbees.com
www.solesbees.com

中国:
Auger Torque China CO., Ltd.
Baozhan Rd, Tongyi Industry Zone
Dongwu, Yinzhou, Ningbo
China 315114
Tel.: + 86 (0) 574 8848 8181
Fax: + 86 (0) 574 8848 8687
Email: john.hu@attachmenttorque.com
www.augertorque.com

Italia:
Hammer S.r.l.
Via Oleifici dell' Italia Meridionale,
lotto G1
IT-70056 Molfetta BA
Tel.: +39 080 337 5317
Email: info@hammerurope.com
www.hammereurope.com

Italia:
Cangini Benne S.r.l.
Via Savio, 29/31 47027
IT-70056 Sarsina FC
Tel.: +39 0547 698020
Fax: +39 0547 698021
Email: cangini@canginibenne.com
www.canginibenne.com

Italia:
Trevi Benne S.p.A.
Via Bergoncino, 18
IT-36025 Noventa Vicentina VI
Tel.: +39 0444 760773
Fax: +39 0444 861182
Email: info@trevibenne.it
www.trevibenne.it

United Kingdom:
Prolec
25 Benson Road,
Nuffield Industrial Estate
Poole, BH17 0GB
Tel.: +44 1202 441 000
Email: enquiries@prolec.co.uk
safe.prolec.co.uk



KINSHOFER
GROUP