

# Clamshell Bucket w/exchangeable shells 19-25t / 41,800-55,000lbs

**C25VE**

Clamshell Bucket with exchangeable shells and vertical cylinders for excavators from 19t / 41,800lbs to 25t / 55,000lbs operating weight - through quick and easy exchange of shells, the C25VE is ideal for different applications, for excavation operations, landscaping, trench digging, handling of logs and more. The shells can be changed in less than four minutes.



- ▷ **Economic solution** as only the shells have to be exchanged for another application. Bucket carrier, hydraulic cylinder and bearings are integrated into the unit.
- ▷ **Long life** is ensured due to the use of 500HB steel in the manufacture of cutting edges.
- ▷ **Reduced wear** resulting from generously dimensioned bearing system.
- ▷ **Excellent digging characteristics** are the result of high closing forces (60kN / 13,200lbf at 35 MPa / 5,070psi operating pressure, varies depending on width).

## Clamshell Bucket C25VE

Type	Width E (mm/in)	Opening A (mm/in)	Height C max.(mm/in)	Length F (mm/in)	Volume (liter/c.y.)	Number of teeth	Weight (kg/lbs)	Load capacity (kg/lbs)
C25VE-42	420 / 16.5	1,940 / 76.4	1,940 / 76.4	1,700 / 66.9	210 / 0.27	3	950 / 2,090	6,000 / 13,200
C25VE-50	500 / 19.7	1,940 / 76.4	1,940 / 76.4	1,700 / 66.9	250 / 0.33	4	980 / 2,156	6,000 / 13,200
C25VE-60	600 / 23.6	1,940 / 76.4	1,940 / 76.4	1,700 / 66.9	305 / 0.40	5	1,010 / 2,222	6,000 / 13,200
C25VE-80	800 / 31.5	1,940 / 76.4	1,940 / 76.4	1,700 / 66.9	410 / 0.54	7	1,080 / 2,376	6,000 / 13,200
C25VE-100	1,000 / 39.4	1,940 / 76.4	1,940 / 76.4	1,700 / 66.9	520 / 0.68	7	1,180 / 2,596	6,000 / 13,200
C25VE-120	1,200 / 47.2	1,940 / 76.4	1,940 / 76.4	1,700 / 66.9	625 / 0.82	9	1,250 / 2,750	6,000 / 13,200

**Package consists of:** clamshell bucket, bolt-on teeth, rotator with hose guard, 2 weld-on eyes, shell exchange aid kit and non-return valve

## Exchangeable Shells C25VE-S

Type	Width E (mm/in)	Volume (liter/c.y.)	Number of teeth	Weight (kg/lbs)	Load capacity (kg/lbs)
C25VE-42S	420 / 16.5	210 / 0.27	3	350 / 770	6,000 / 13,200
C25VE-50S	500 / 19.7	250 / 0.33	4	390 / 858	6,000 / 13,200
C25VE-60S	600 / 23.6	305 / 0.40	5	420 / 924	6,000 / 13,200
C25VE-80S	800 / 31.5	410 / 0.54	7	490 / 1,078	6,000 / 13,200
C25VE-100S	1,000 / 39.4	520 / 0.68	7	580 / 1,276	6,000 / 13,200
C25VE-120S	1,200 / 47.2	625 / 0.82	9	650 / 1,430	6,000 / 13,200

**Package consists of:** exchangeable shells, exchange aid kit and extraction tool for pin

**Note:** special shells available on request

## KINSHOFER Rotator

Continuous rotation and two oil passages. Overload protection is ensured by pressure relief valves.

Type	Upper connection (width x pin-Ø) (mm/in)	Torque (Nm/ft.lbs)	Bending moment max. (Nm/ft.lbs)
KM 15 F340-70	180 x 70 / 7.1 x 2.8	3,000 / 2,212.5	25,000 / 18,437.5

## Accessories

Type	Description
KM 501 19t-60t	upper suspension without pendulum damper
KM 511 19t-60t	upper suspension with pendulum damper
KM 510 19t-60t	single pendulum damper
KSW21/25 cardanic	adapter for system L-Lock KMS21/25L / KHS21/25L incl. cardan link excl. pendulum damper - up to 40t/88,000lbs adapters for quick change systems from other manufacturers or different sizes on request
KM 680 C25VE	scraper

## Requirements of carrier machine

<b>Operating pressure (open/close):</b>	<b>max. 35 MPa (350 bar) / 5,070 psi</b>
<b>Pump capacity (open/close):</b>	75 - max. 150 l/min / 20 - max. 40 GPM
<b>Operating pressure (rotate):</b>	<b>max. 32 MPa (320 bar) / 4,640 psi</b>
<b>Pump capacity (rotate):</b>	20 - max. 50 l/min / 5 - max. 13 GPM

## Technical drawing

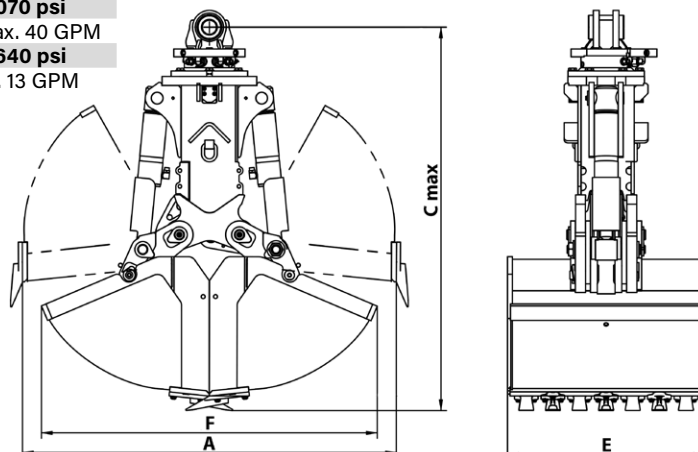

Request? [exc@kinshofer.com](mailto:exc@kinshofer.com)